

VALVOLE A FARFALLA PER GAS METANO - Cod.2143

BUTTERFLY VALVES FOR NATURAL GAS USE - code 2143

DESCRIZIONE

Valvole a farfalla ad asse centrato con manicotto in NBR a tenuta perfetta.

Dotate di struttura robusta con corpo in ghisa sferoidale, sono realizzate in conformità alla normativa UNI 11354, relativa alle valvole a farfalla di intercettazione del gas su reti di distribuzione e trasporto con pressione di esercizio fino a 5 bar.

CARATTERISTICHE COSTRUTTIVE

- Tipologia: Lug mod. **VF205**
- Corpo in GGG50 con verniciatura epossidica
- Manicotto in NBR
- Disco in GGG50 nichelato
- La sede ricopre completamente il corpo, isolandolo dal fluido
- Albero in acciaio inox AISI 416
- Design: API 609, UNI EN 593
- Classe di tenuta VI per ANSI FCI 70-2 (tenuta perfetta)
- Flangia superiore UNI EN ISO 5211
- Flange di accoppiamento PN16
- Manovra: leva con selettore a 10 posizioni o riduttore manuale con volantino

SPECIFICHE DI COLLAUDO

- Pressione di esercizio max 16 bar
- Temperature di esercizio -10°C + 80°C
- Prove di collaudo secondo API 598
 - Prova idraulica di tenuta a 18 bar a 20°C
 - Prova idraulica del corpo a 24 bar
- Prova pneumatica della sede a 6 bar

OPZIONI

- Prolunga asta di manovra
- Corpo in acciaio al carbonio
- Altre esecuzioni speciali a richiesta
- Attuatori pneumatici o elettrici, posizionatori, box fine corsa, elettrovalvole

DESCRIPTION

Centric butterfly valves with NBR liner, no leakage. With robust and maintenance-free design, they are manufactured according to UNI 11354, regarding shut off butterfly valves for gas supply on piping up to 5 bar of working pressure.

CONSTRUCTION FEATURES

- Type: Lug mod. **VF205**
- GGG50 body with epoxy coating
- NBR liner
- GGG50 nickel plated
- The seat completely covers the body, isolating it from the fluid
- AISI 416 stainless steel stem
- Design: API 609, UNI EN 593
- Sealing class VI as per ANSIFCI 70,2 (no leakage)
- Upper flange UNI EN ISO 5211
- PN16 coupling flanges
- Operation: lever with 10-positions notch plate or gearbox with handwheel

TEST SPECIFICATIONS

- Max operating pressure 16 bar
- Working temperature range -10°C to + 80°C
- Test according to API 598
 - Hydraulic seal test at 18 bar at 20°C
 - Hydraulic body test at 24 bar
- Pneumatic seat test at 6 bar

OPTIONAL

- Shaft extension
- Carbon steel body
- Other special executions on request
- Pneumatic or electric actuators, positioners, limit switch boxes, solenoid valves



Descrizione/Description	Materiale/Material
Corpo/Body	GGG50
Disco/Disc	GGG50
Albero/Shaft	AISI 410
Sede/Seat	NBR

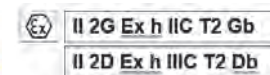

DIMENSIONI / DIMENSIONS

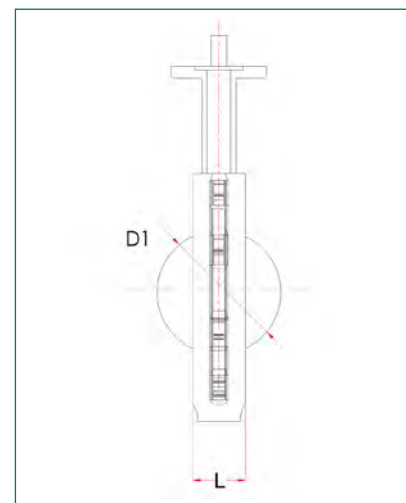
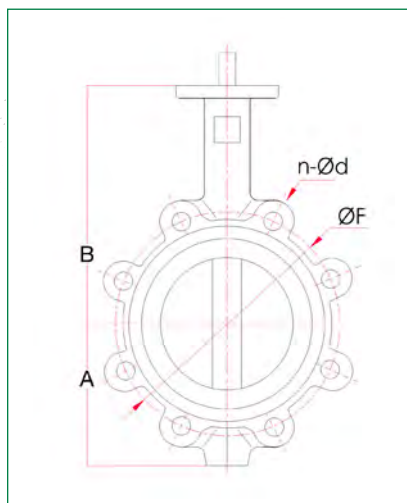

Misura/Size		Dimensioni/Dimensions						Basetta Upper flange	Peso Kg. /Weight kgs.	
DN	inch	A	B	L	D1	PN16		ISO 5211	Leva Lever	Gear
						ØF	n-Ød			
40	1"1/2	75	145	33	42	110	4-M16	F05	3,6	6,6
50	2"	83	162	43	53	125	4-M16	F05	3,8	6,8
65	2"1/2	89	175	46	65	145	4-M16	F05	4,2	7,2
80	3"	95	181	46	79	160	8-M16	F05	4,7	7,7
100	4"	114	200	52	104	180	8-M16	F07	9,0	12,0
125	5"	127	213	56	123	210	8-M16	F07	10,9	14,4
150	6"	140	225	56	155	240	8-M20	F07	14,9	18,4
200	8"	173	260	60	202	295	12-M20	F10	18,2	25,2
250	10"	203	292	68	250	355	12-M24	F10	26,8	35,8
300	12"	240	337	78	301	410	12-M24	F10	40,0	49,0

**ORGANI DI MANOVRA
OPERATING MECHANISM**

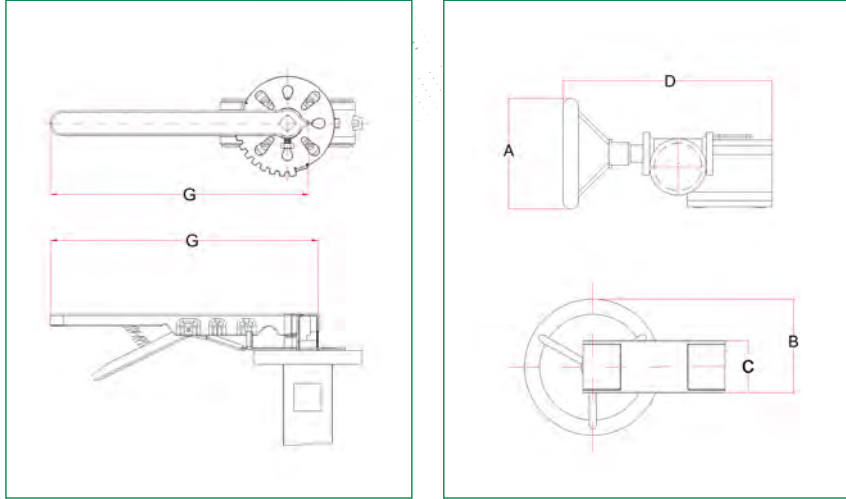

**FLANGIA SUPERIORE E MOMENTO TORCENTE
UPPER FLANGE & TORQUE VALUES**

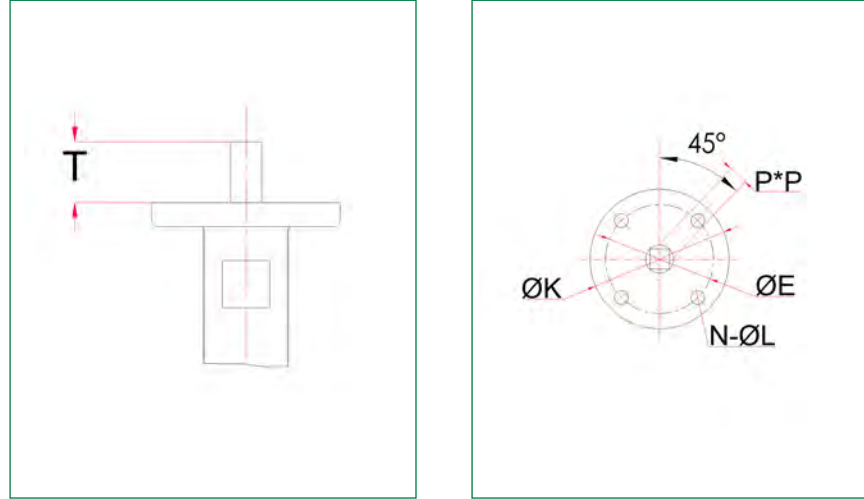

Misura/Size		Dimensioni/Dimensions				
DN	inch	A	B	C	D	G
40	1"1/2	150	126	75	204,5	250
50	2"	150	126	75	204,5	250
65	2"1/2	150	126	75	204,5	250
80	3"	150	126	75	204,5	250
100	4"	150	126	75	204,5	270
125	5"	150	126	75	204,5	270
150	6"	150	126	75	204,5	270
200	8"	300	176	86	325	360
250	10"	300	176	86	325	360
300	12"	300	199	83	308	520

Misura/Size		Flangia superiore Upper flange			T	P	Momento torcente (Nm) Torque (Nm)		
DN	inch	K	E	n-Ød			PN 6	PN 10	PN 16
40	1"1/2	70	50	4-7	32	9	8,7	9,5	10
50	2"	70	50	4-7	32	9	9,6	12	12
65	2"1/2	70	50	4-7	32	9	14,5	15	15
80	3"	70	50	4-7	32	9	21	22	28
100	4"	90	70	4-9	32	11	35,3	37	43
125	5"	90	70	4-9	32	14	47,5	58	68
150	6"	90	70	4-9	32	14	84,1	94	103
200	8"	125	102	4-12	32	17	127	132	173
250	10"	125	102	4-12	45	22	210	228	286
300	12"	140	102	4-12	45	22	245	287	429

NOTA: fattore di sicurezza **ESCLUSO**: per il corretto dimensionamento rivolgersi all'ufficio tecnico
NOTE: safety factor **EXCLUDED**: for correct sizing please contact the technical office

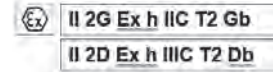

VALORI Kv
Kv VALUES

Misura Size		ANGOLO DI APERTURA APERTURE ANGLE								
DN (mm)	inch	10°	20°	30°	40°	50°	60°	70°	80°	90°
40	1"1/2	0,1	4,3	10	21	39	55	78	108	116
50	2"	0,1	4,3	10	21	39	55	78	108	116
65	2"1/2	0,2	6,9	17	32	56	84	124	176	190
80	3"	0,3	10	19	34	60	100	158	237	260
100	4"	0,4	15	31	67	120	198	314	471	517
125	5"	0,7	25	53	115	204	338	534	802	881
150	6"	1,7	39	82	177	316	522	826	1239	1361
200	8"	2,6	77	162	352	627	1036	1641	2460	2703
250	10"	3,4	130	276	598	1066	1765	2793	4189	4603
300	12"	4,3	202	427	924	1647	2726	4315	6470	7112

Kv = valori di flusso in m3/h alla pressione differenziale di 1 bar con acqua a 20°C;
Kv = flow values in m3/h at 1 bar differential pressure with water at 20°C;
CV =valori di flusso in galloni/minuto alla pressione di 1 psi con acqua a 20°C; CV= 1,16Kv);
CV =flow values in gallons/minute at 1 psi, with water at 20°C; CV= 1.16Kv)

BULLONERIA PER INSERIMENTO TRA FLANGE
UNI PN 16
BOLTS FOR UNI PN 16 FLANGES

Misura Size		VF105 LUG	
		PN16	
DN (mm)	inch	N°	Misura Viti Screw Size
40	1"1/2	4	M16x30
50	2"	4	M16x35
65	2"1/2	4	M16x35
80	3"	8	M16x35
100	4"	8	M16x40
125	5"	8	M16x45
150	6"	8	M20x50
200	8"	12	M20x50
250	10"	12	M24x60
300	12"	12	M24x65



Via E. Fermi, 490 (SP11 ex SS11) | 24045 Fara Gera D'Adda (BG) Tel.+39 0363 360525 - Fax. +39 0363 65655
www.italthermo.it - info@italthermo.it

Come raggiungerci facilmente: Autostrada A35 BRE.BE.MI uscita Treviglio (BG)